

The difference matters
The difference matters



HF Welding machines for high demand
in performance and accessibility

FIAB 900

More Efficient More Exact More Flexible

FIAB HF AB is the leading manufacturer of travelling head HF welding machines. FIAB 900 series is the latest development from FIAB.

The FIAB 900 series have been modified in many aspects.

FIAB HF AB always puts efficiency, quality, and safety in the first place.

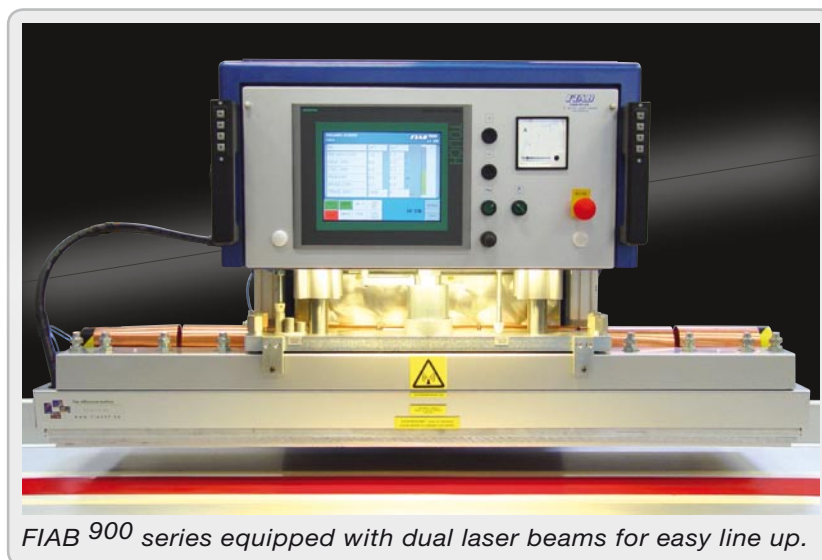

FIAB 900 series equipped with dual laser beams for easy line up.



FIAB HF welding machine type FIAB 900 has no limits for stored information. A huge amount of recipes can easily be stored on Compact Flash Memory Card. The Compact Flash Memory Card can be read by inexpensive card readers. Recipes can be created on a Lap Top Computer. You can order the machine in stationary or movable version. For the Movable version, FIAB has developed a track and table system.

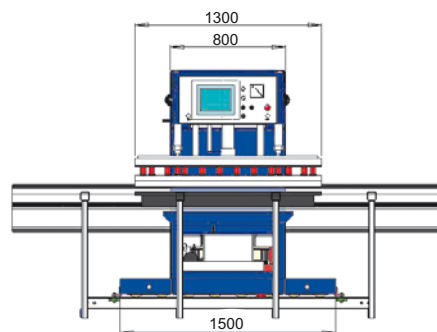
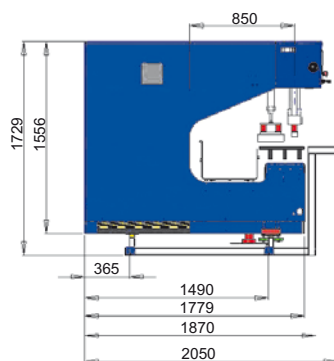

FIAB 900 (moveable)

Track Table and rear trough, including programmable drive, integrated power and air lines in rack table (note: table- and rail-sections will be delivered in 2 meters section and it is easy to change length in the future).

FIAB 900 machinery is delivered with joy stick for easy operation of main functions.

FIAB 900 has a Cooling / Heating system unit for stabilizing electrode temperature consisting of condenser tube in tool head, cool, Thermostat, Circulation Pump and Clock function in touch screen.

FIAB HF AB

Datavägen 5, Box 10012
SE-453 29 Lysekil, Sweden
Phone: +46 523 15040, Fax: +46 523 12228
www.fiabhf.se e-mail: info@fiabhf.se

FIAB

The difference matters
The difference matters

FIAB 900

Technical data *



Model	FIAB 910	FIAB 913	FIAB 917	FIAB 922	FIAB 926
Max output	10 kW	13 kW	17 kW	22 kW	26 kW
Main fuse (400 V, 3 phase)	32 A	40 A	50 A	63 A	80 A
Voltage	Standard 3 x 400 V, Other voltage can be delivered to customer request.				
Operating frequency	27,12 MHz +/- 0,6%				
Arc suppressor (Anti flash)	FIAB security system for instant interruption of HF.				
Computer system	SIEMENS S7 300				
Touch Screen	SIEMENS TP 270				
Generator Cooling system	Air				
Pressure adjustable (6 bar)	1200 kg (2645 lb)	2000 kg (4409 lb)	2000 kg (4409 lb)	2000 kg (4409 lb)	2000 kg (4409 lb)
Stroke	100 mm (stroke selector)				
Air consumption / cycle	35 litre free air / cycle (up and down stroke)				
Pneumatic press unit	2 pillars ball bushing guided.				
Driving unit (moveable only)	3 phase motor with gear box, frequency inverter controlled.				
Tool holder	700, 1000, 1300, 1500, 1700 or 2000 mm (other dimensions on request)				
Tool attachment	FIAB adapter plate system for easy and exact changing, pneumatic lock.				
Approx weight FIAB 900	1520 Kg (3351 lb)				
Approx weight FIAB track & table	Approx 50 Kg / meter (33,6 lb/ft)				
PIN login code	Standard	Standard	Standard	Standard	Standard
Programmable with memory card	Standard	Standard	Standard	Standard	Standard
Joystick	Standard	Standard	Standard	Standard	Standard
Cooling / heating unit	Option	Option	Option	Option	Option
Diode laser unit	Option	Option	Option	Option	Option
Tape dispenser	Option	Option	Option	Option	Option
Cutting unit	Option	Option	Option	Option	Option
Remote control	Option	Option	Option	Option	Option
Foot pedal (stationary)	Option	Option	Option	Option	Option
Impulse welding	Option	Option	Option	Option	Option

* Specifications and design may be changed without notice.



FIAB

FIAB HF AB, SE-453 29 Lysekil, Sweden
Phone: +46 523 15040 Fax +46 523 12228
www.fiabhf.se, e-mail: info@fiabhf.se